

Thesis Proposal

The University Medical Center of Princeton

12/9/2011

Faculty Advisor: Professor Parfitt

Alexander J. Burg

Structural Option

The Pennsylvania State University



Executive Summary

The University Medical Center of Princeton (UMCP) is a seven story, 92' tall building that services the medical needs for Princeton students and the members of the surrounding community in Plainsboro, NJ. The superstructure is composed of a steel framing system with composite deck, and the lateral system is designed with a combination of braced frames and moment frames.

The past technical reports show that the structure is adequate to support all of the gravity and lateral load forces. This proposal states the problems of the existing composite steel deck system, and the solution of changing the structure to a one-way concrete slab floor system. The redesign should help reduce overall cost of the project and also reduce vibration in the system. The cost of fireproofing is non-existent since you do not need to fireproof concrete. Cost of formwork is going to add to the budget, but reusing the formwork should keep the price low. Since the cost and schedule are going to be greatly impacted, breadth one, construction impact and cost analysis will compare which design is most viable. Also, the redesign of the building might change the bay spacing. A minor redesign of the floor layout will have to be considered, which leads into the next breadth topic of architecture. Exposing circular concrete columns will enhance the space keeping the curvature aspect of the building mimicking the curvature of the curtain wall. The lateral system will also be designed for concrete moment frames in the long direction. Connecting the concrete moment frames to the curtain wall will affect the aesthetics of the building. More research and design will come through for the look of the curtain wall with the moment framing.

The tasks written in the report will need to be followed thoroughly to keep on track with the milestones. A schedule was created to help further reach the goals of this proposal. Constant research and hard work will bring this proposal to life by the end of next semester.

Contents

Executive Summary..... 1

Building Introduction 3

Structural Overview 4

FOUNDATIONS 4

FLOOR & FRAMING SYSTEMS 4

LATERAL SYSTEMS..... 5

CODES/MEANS USED..... 6

Problem Statement..... 7

Proposed Solutions 7

BREADTH TOPIC 1- CONSTRUCTION IMPACT AND COST ANALYSIS 7

BREADTH TOPIC 2- ARCHITECTURE LAYOUT 7

Tasks & Tools..... 8

Schedule..... 9

Conclusion..... 10

Appendices..... 11

 Appendix 1: Architectural Sections & Plans..... 12

Building Introduction

Princeton University Medical Center was in a big need of change. The rapid growth of people plus the outdated building design and equipment were the main reasons to upgrade their old medical center.

The University Medical Center at Princeton (UMCP) will also be joining the Pebble Project. Pebble Project is a research effort between The Center for Health Design and selected healthcare providers to measure the layout and design of a hospital and how it can increase quality care and economic performance. The design of this building is not just for looks, but to help operate a hospital in a healthy and efficient manner.

This six story tall building has a long and curving body that encases the parking lot to draw people into the building. Lighting is not going to be an issue during the day as the glass curtain wall is used on the south face of the building. Furthermore, it will provide a view to the outside for all the patients and workers in the building. The curtain wall is framed with aluminum reliefs and metal panels. The West and East elevations have a CMU ground face with a brick façade on the top floors, and there are very few windows since these walls are framed with steel bracing. The mechanical equipment is encased in 13.5' parapets. Floors two through six almost mimic each other in framing and room layout. The entrance of the building has a wide atrium open to the second floor with interior wood shading panels. The overall design of the building is simple, sleek, and efficient.



FIGURE 1: UMCP SITE LOCATION SHOWN IN BLUE SATELLITE PHOTO COURTESY OF GOOGLE MAPS

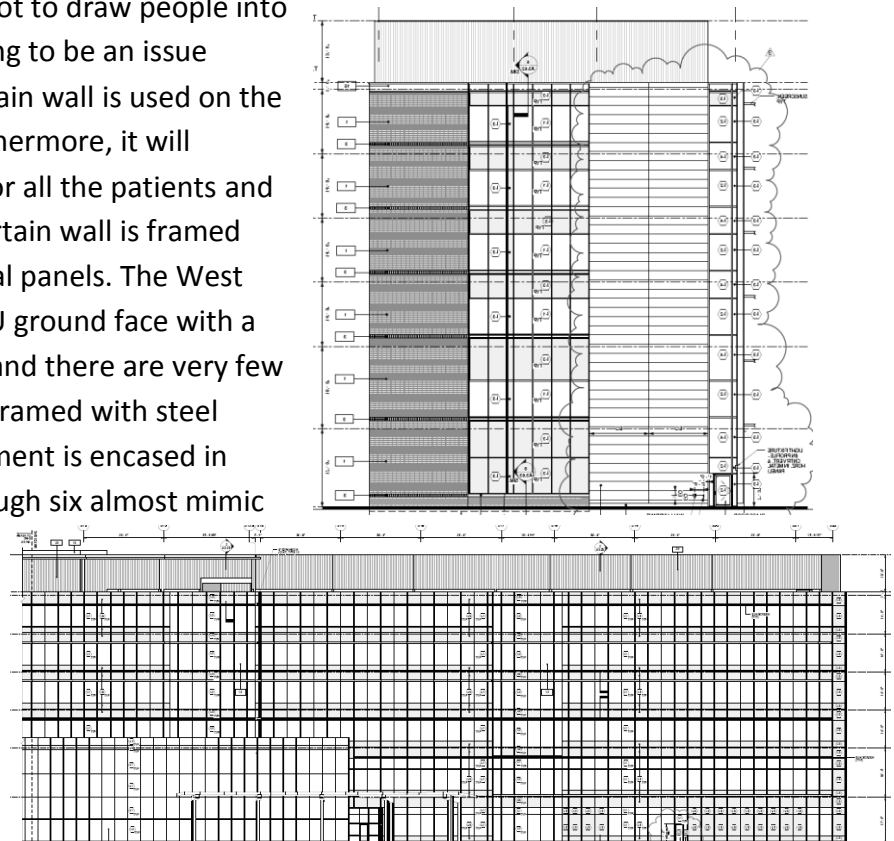

FIGURE 2: EAST AND SOUTH BUILDING ELEVATIONS DRAWINGS COURTESY OF TURNER CONSTRUCTION

Structural Overview

The foundation plan for the University Medical Center is built on 4" to 5" Slab-On-Grade basement floor with interior concrete piers stabilizing wide flange columns, and an exterior 2' thick foundation wall partially incasing mini tension piles. The design of the superstructure is primarily steel framing. The framed floors consist of a 3 span 3 ¼" lightweight concrete composite decking system with composite steel framing. Roof decking is type B 1 ½" galvanized metal deck, and 6 ½" normal weight concrete composite metal deck for the roof Penthouse area. There is also a massive curtain wall spanning the South end of the curving building, but this will not be analyzed in this technical report.

FOUNDATIONS

According to drawing S3.01 all the subgrade footings were poured under the supervision of a registered Soils Engineer. The capacity of the soils, shown in the boring test specifications, came out to be 4,000psf and 8,000psf for the compacted/native soils (medium-dense/stiff) and decomposed bedrock respectively. The spread footings support wide flange columns, varying from W10x54 to W14x311, to anchor the superstructure (Refer to Figure 3 for more detail). The spacing for the foundation columns is not consistent throughout the basement, which that is the reason for the varying column sizes. Figure 3 shows a typical spread footing supporting a steel column. Outlying the basement is a 2' thick foundation wall with mini tension piles that relieves up to 150kips of tension from the concrete bearing wall.

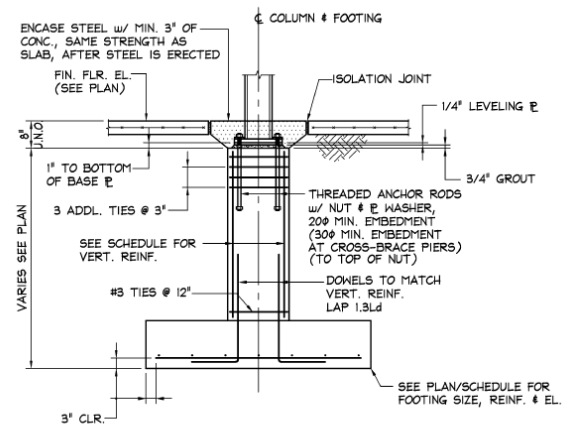

TYPICAL COLUMN FOOTING WITH PIER

FIGURE 3: TYPICAL COLUMN FOOTING WITH PIER
DRAWING COURTESY OF TURNER CONSTRUCTION

Concrete Strengths:

- 3,000psi- Spread Footings, Wall Footings, Foundation Wall, & Retaining Walls
- Minimum of 3,000psi- Piers-match wall strength
- 3,500psi- Slab-On-Grade and Slab-On-Deck

Rebar Design:

- ASTM A615- Deformed Bars Grade 60
- ASTM A185- Welded Wire Fabric

FLOOR & FRAMING SYSTEMS

A typical beam spanning in the North/South direction, consists of a 26' span then a 15' span, and finally back to a 26' span. The East/West girders span 29 ½' typically and Appendix 1 helps

better understand the layout of the building. Floors two through six do not change in design other than the column thickness, all of the floors use a 3 span 3 ¼" lightweight concrete composite decking. This creates a one-way composite flooring system connected to composite beams. Even though the first floor has an additional atrium, the decking is still consistent to the floors above. Figure 4 shows the wide flange beams used in each span.

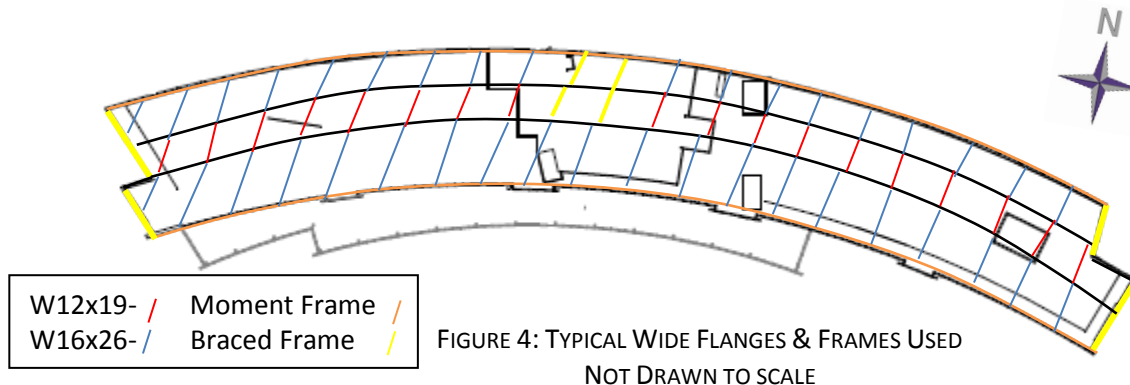

The infill beams are usually at a spacing of 9.8' and they range from W16x26 for the 26' spans or W12x19 for the 15' spans. The girders typically span 29.5' and vary from W24x55 on the exterior girders to W21x44 on the interior girders. These composite beams use ¾" bolts to help anchor the decking. The typical bays then come out to be either 29.5'x26' or 29.5'x15'. There are also two transfer beams on the on column lines N2 and S3 to account for columns that do not line up on the first to second floor.

Steel Design:

- ASTM A992- Wide Flanges
- ASTM A500- Rectangular/Square Hollow Structural Sections Grade B, Fy=46ksi
- ASTM A500 or ASTM A53- Steel Pipe Type E or S Grade B
- ASTM F1554- Anchor Rods Grade 55

LATERAL SYSTEMS

The UMCP lateral systems design was comprised of typical steel moment frames in the East/West direction and steel concentrically braced frames in the North and South direction. Those framing systems only occurred on the perimeter of the building. Around the elevator shaft is another place where the design is concentrically braced. The lateral forces will travel into the composite deck, and then through the wide flange beams or HSS braces into the columns to the piers to then dissipate into the ground.

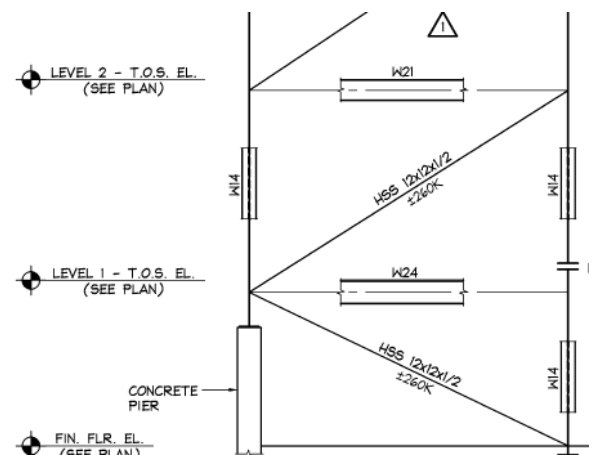

CODES/MEANS USED

This building fit into an Occupancy Category III. Any Hospital/Medical Center needs to be designed with an Occupancy Category III as a safety factor.

Original design codes used on this building were:

- 2006 International Building Code (IBC) with New Jersey Uniform Construction Code
- 2006 International Mechanical Code (IMC)
- 2005 National Electric Code (NEC) with local amendments
- 2006 International Energy Conservation Code with other local amendments
- 2006 International Fuel Gas Code with local amendments
- New Jersey Department of Health and Senior Services - "Licensing Standards for Hospitals, N.J.A.C 8.43G" and the 2006 Edition - "Guidelines for Design and Construction of Hospital and Health Care Facilities."

Design codes used for Thesis Calculations:

- ASCE 7-10 Minimum Design Loads for Buildings and other Structures
- American Institute of Steel Construction, 14th Edition AISC Steel Construction Manual
- 2008 Vulcraft Steel Roof & Floor Deck Manual

Problem Statement

Through the past three technical reports, it has been determined that the structural system of the University Medical Center of Princeton is adequate to resist gravity loads and lateral loads for the building code criteria. Vibration is one criterion where the hospital can improve, since the superstructure is composite steel deck. Technical report two showed that this floor structure had significant deflection compared to the other systems analyzed. Additional cost is also added to steel structures to reach the safety requirement of a two hour fire rating. The floor system's thickness impedes the floor to ceiling heights, adding costs to the project for unused space. Investigating the second technical report will help with the redesign process for an alternative system. Redesigning the structure to concrete will impact the column layout, so the floor layout may need to be adjusted.

Proposed Solutions

Because concrete structures are more rigid than steel structures, changing the design to a solid one way lab should limit the deflection and vibration issues in UMCP. This will create a more comfortable atmosphere for the patients due to less vibration and better noise control; performance in surgery rooms could also improve due to the same enhancements. A more in-depth research on vibration control in hospital surgery rooms will need to be conducted to reach the needs of the hospital. Concrete does not need to be fireproofed, and depending on the column layout the floor to ceiling height could decrease. Therefore, lifespan costs of the hospital should decrease. A cost and schedule comparison will be completed to determine which building system is more cost effective. The formwork and schedule of the project would impact the cost as well. Reusing formwork should maintain a low project cost.

BREADTH TOPIC 1- CONSTRUCTION IMPACT AND COST ANALYSIS

There will be a great impact on the project cost and scheduling for the redesign of the building. Erecting steel and placing concrete will require different construction scheduling due to the placing of the formwork and waiting for the concrete to cure. Therefore, an accurate schedule of the redesign will be created for the new construction process. The cost of the redesign will include items such as base material cost, labor teams, and formwork. For that reason, an analysis of the new cost and schedule will be necessary to compare with the existing design.

BREADTH TOPIC 2- ARCHITECTURE LAYOUT

Redesigning the new floor system may have an impact on the bay sizes, but the original layout of the bay sizes is very logical for the building use. In the new design bay sizes will not differ drastically from the original design, but this may create places where a concrete column is exposed. This may be aesthetically/visually pleasing if half of a circular column is shown jutting out of a wall, giving the room/corridor a different spatial feel. Those protruding columns may

also be functional if you place a table around it for the doctors/nurses to utilize. Also, for the lateral system, the steel moment frames are going to be designed as concrete moment frames. Then the glass curtain wall will still be functional. There will be much more research in this design for connecting the curtain wall to the concrete frame, and making the design aesthetically pleasing while meeting the codes and standards.

Tasks & Tools

- ❖ Structural Depth
 - Research design criteria for hospital/surgery room vibration
 - Perform hand calculations
 - Determine wind and seismic loads with the new weight of the building
 - Perform Lateral analysis
 - Design lateral force resisting system
 - Confirm preliminary member sizes
 - Check the existing foundation to see if it is still adequate
- ❖ Breadth 1: Construction Impact and Cost Analysis
 - Obtain existing cost and schedule information
 - Determine labor cost
 - Determine material cost
 - Compare the existing cost and schedule with the redesign
- ❖ Breadth 2: Architecture Layout
 - Determine a column layout close to the existing
 - Make sure the space is well laid with the new column design
 - Incorporate concrete columns into a space for aesthetic looks and for doctor/nurse stations
 - Construct Revit model
 - Design curtain wall with lateral system
- ❖ Organize report and final presentation

Conclusion

This proposal focuses on an in depth study of redesigning the floor system from steel composite deck to one way flat slab. This will affect the cost and schedule of the project, therefore the first breadth, will address the construction impact and cost. The new cost analysis and schedule will be compared to the original to see if it would have made more sense to design the structure with one-way concrete slab system. The second breadth deals with the architectural layout of the building. After redesigning the structure the bay sizes may vary. The concrete columns will play a part in the space; some columns will act as a support for a table for nurses and doctors to use. The lateral system will change as well, but the only way that will affect the architecture is that it may be exposed so it can be seen through the curtain wall. This proposal includes a schedule to help stay on track of the owners milestones. Much time and dedication plus research will help turn this proposal into reality

Appendices

Appendix 1: Architectural Sections & Plans

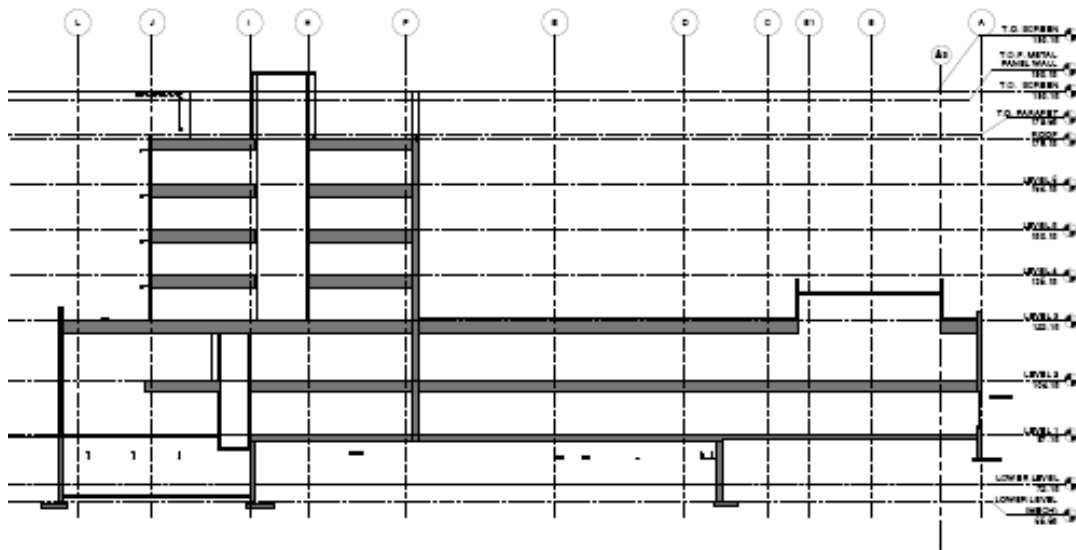

EAST/WEST SECTION

COURTESY OF TURNER CONSTRUCTION

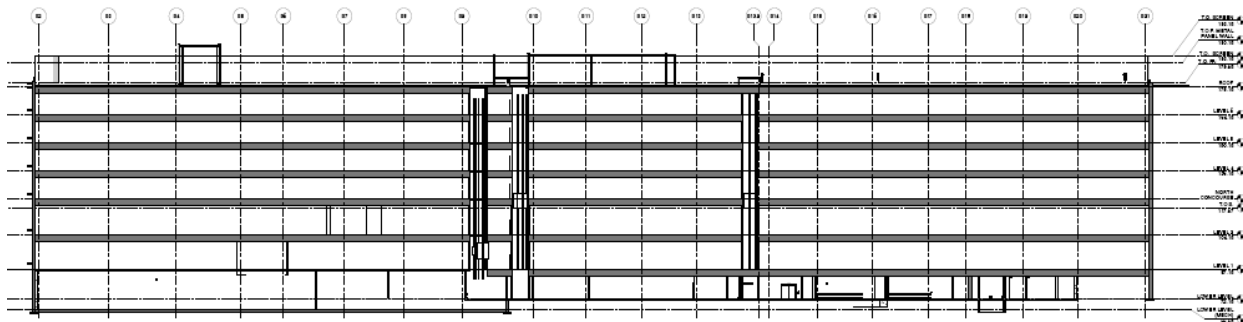

NORTH/SOUTH SECTION

COURTESY OF TURNER CONSTRUCTION

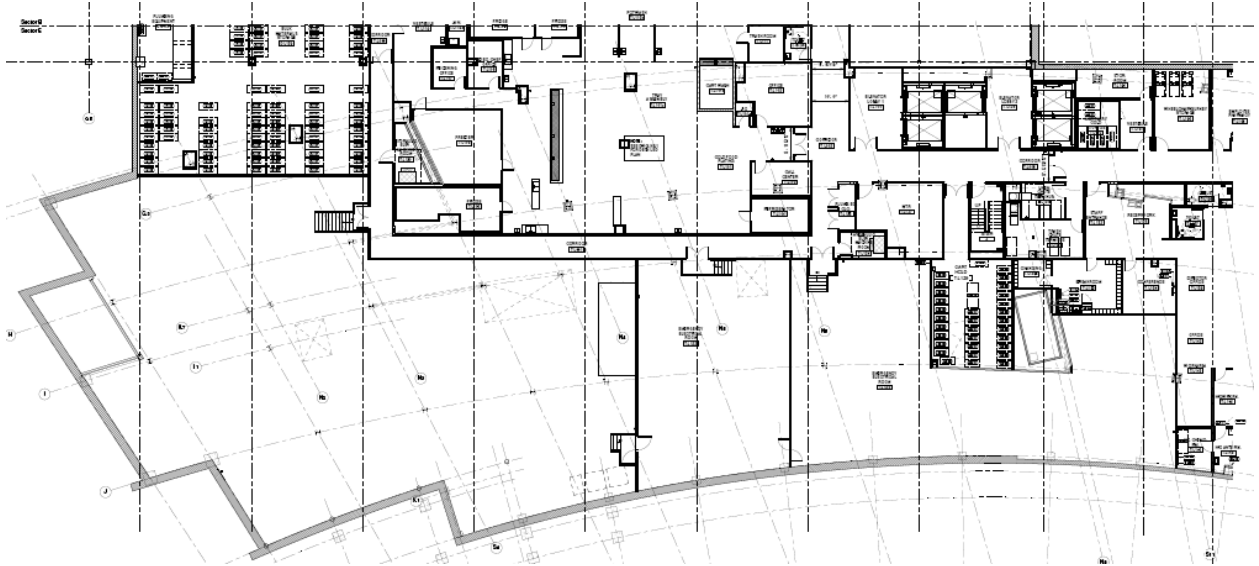

TYPICAL WEST END FLOOR PLAN

COURTESY OF TURNER CONSTRUCTION



TYPICAL WEST END FLOOR PLAN

COURTESY OF TURNER CONSTRUCTION